

L:
 CBL-HFD3SAB5C-4m 4000mm±30mm
 CBL-HFD3SAB6C-5m 5000mm±30mm
 CBL-HFD3SAB6C-6m 6000mm±30mm

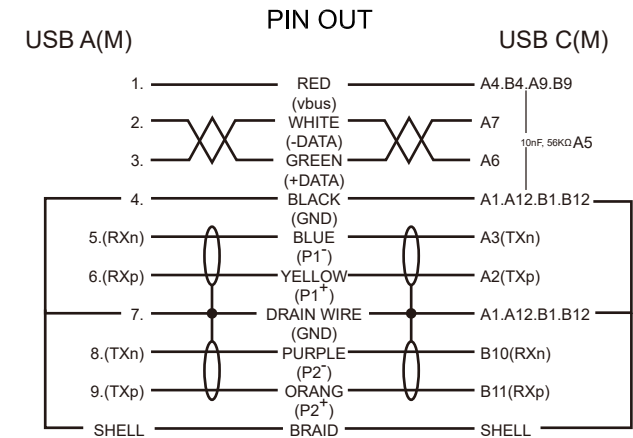

No	MATERIALS LIST:
1.	CABLE: 3 x (2 x 28 AWG)ST + 2 x 26 AWG O.D.:.6.1mm COLOR:RED LILAC
2.	CONNECTOR:USB 3.0 A/M, 9P, BLUE INSULATOR SOLDER TYPE, NICKEL PLATED SHELL
3.	CONNECTOR:USB 3.1 TYPE-C, MALE, NICKEL PLATED SHELL
4.	PVC MOLDED HOUSING, BLACK COLOR
5.	

Jargy part no.	Client part no.	Approved	SCALE	UNIT
CBL-HFD3SAB5C-xm				mm
Drawing Name		Drawn	Date	REV.
USB 3.1 GEN 1 A to C Cable M/M				1.0

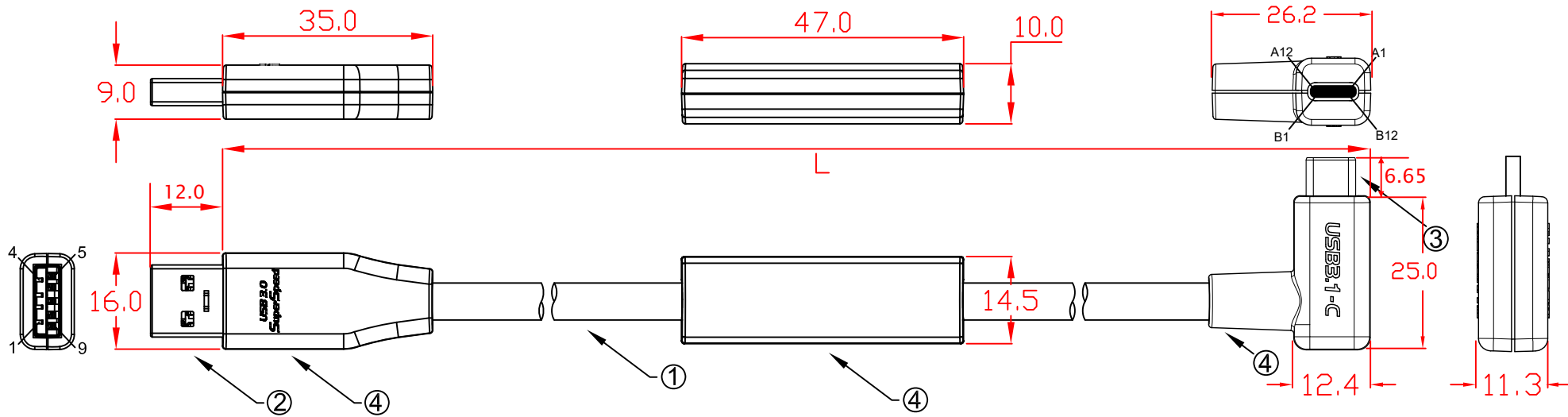

L:
 CBL-HFD3SAB5C-4mLRA 4000mm±30mm
 CBL-HFD3SAB5C-5mLRA 5000mm±30mm
 CBL-HFD3SAB5C-6mLRA 6000mm±30mm

No	MATERIALS LIST:
1.	CABLE: 3 x (2 x 28 AWG)ST + 2 x 26 AWG O.D.:.6.1mm COLOR:RED LILAC
2.	CONNECTOR:USB 3.0 A/M, 9P, BLUE INSULATOR SOLDER TYPE, NICKEL PLATED SHELL
3.	CONNECTOR:USB 3.1 TYPE-C, MALE, NICKEL PLATED SHELL
4.	ABS ASSEMBLY HOUSING, BLACK COLOR

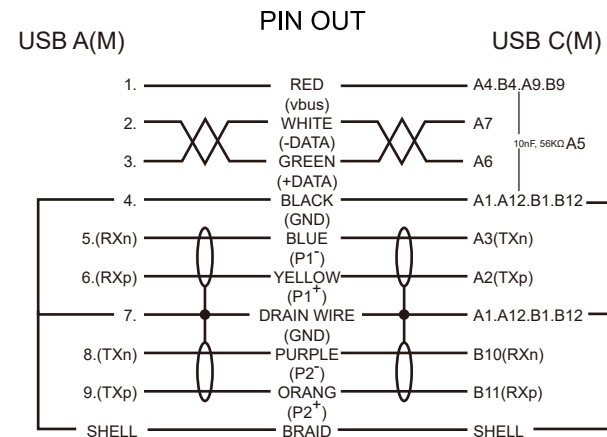

Jargy part no.	Client part no.	Approved	SCALE	UNIT
CBL-HFD3SAB5C-xmLRA				mm
Drawing Name		Drawn	Date	REV.
USB 3.1 GEN 1 A to C Cable M/M				1.0

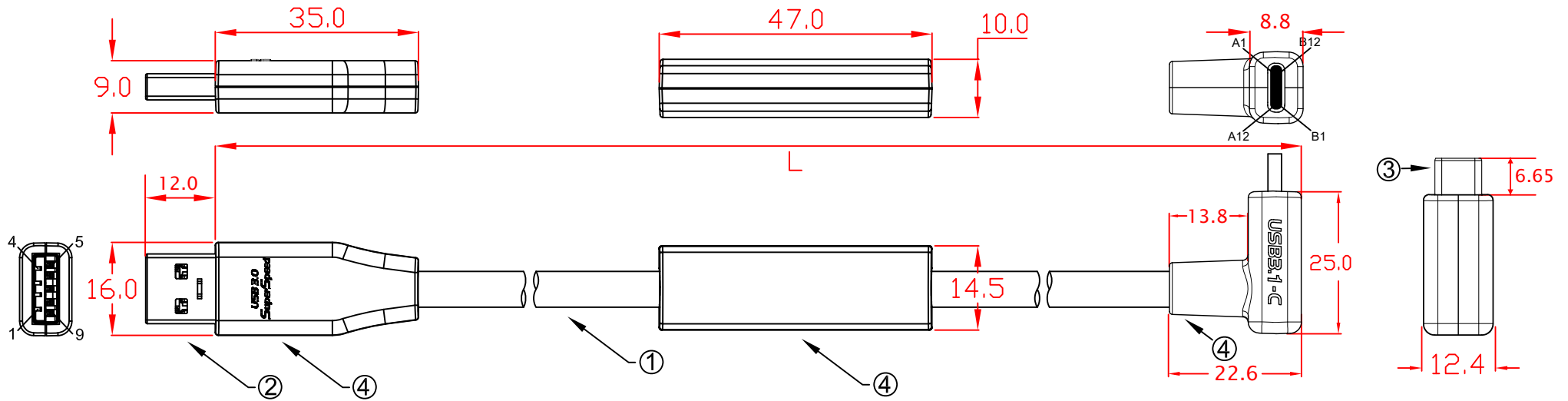

L:
 CBL-HFD3SAB5C-4mUDA 4000mm±30mm
 CBL-HFD3SAB5C-5mUDA 5000mm±30mm
 CBL-HFD3SAB5C-6mUDA 6000mm±30mm

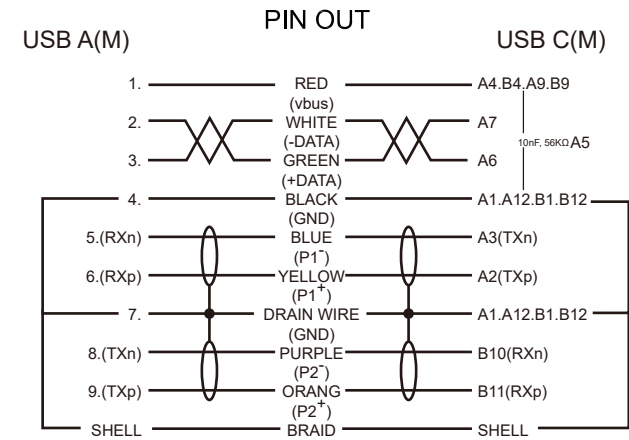

No	MATERIALS LIST:
1.	CABLE: 3 x (2 x 28 AWG)ST + 2 x 26 AWG O.D.:.6.1mm COLOR:RED LILAC
2.	CONNECTOR:USB 3.0 A/M, 9P, BLUE INSULATOR SOLDER TYPE, NICKEL PLATED SHELL
3.	CONNECTOR:USB 3.1 TYPE-C, MALE, NICKEL PLATED SHELL
4.	ABS ASSEMBLY HOUSING, BLACK COLOR

Jargy part no.	Client part no.	Approved	SCALE	UNIT
CBL-HFD3SAB5C-xmUDA				mm
Drawing Name		Drawn	Date	REV.
USB 3.1 GEN 1 A to C Cable M/M				1.0

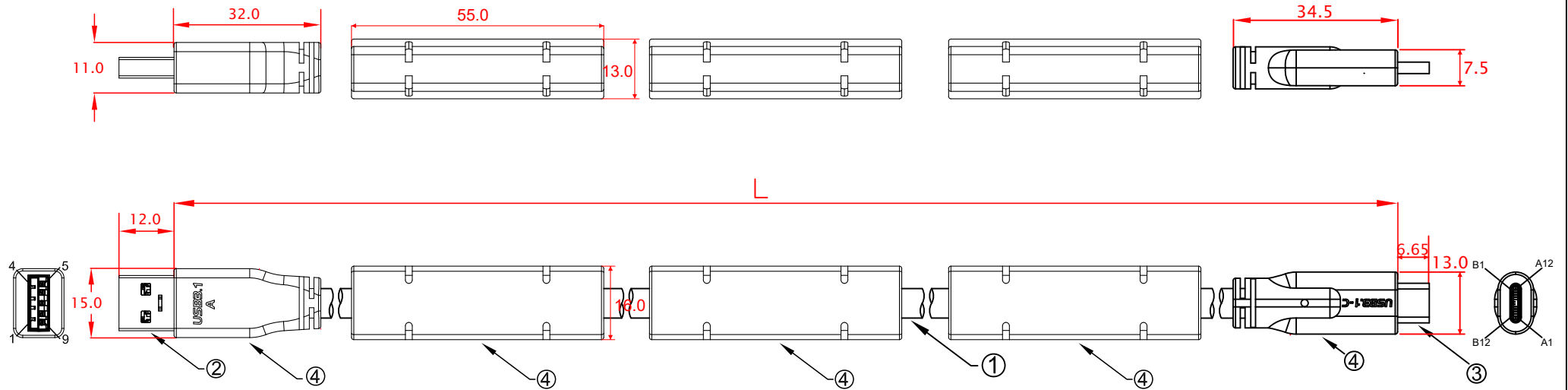

L:
 CBL-HFD3SAB5C-7m 7000mm±50mm
 CBL-HFD3SAB5C-8m 8000mm±50mm
 CBL-HFD3SAB5C-9m 9000mm±50mm

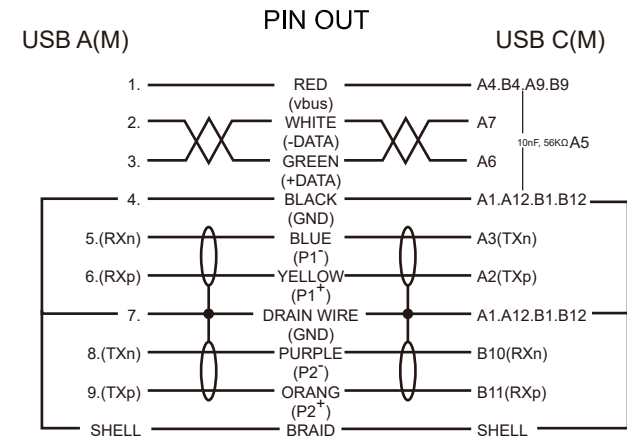

No	MATERIALS LIST:
1.	CABLE: 3 x (2 x 28 AWG)ST + 2 x 26 AWG O.D.:.6.1mm COLOR:RED LILAC
2.	CONNECTOR:USB 3.0 A/M, 9P, BLUE INSULATOR SOLDER TYPE, NICKEL PLATED SHELL
3.	CONNECTOR:USB 3.1 TYPE-C, MALE, NICKEL PLATED SHELL
4.	PVC MOLDED HOUSING, BLACK COLOR
5.	

Jargy part no.	Client part no.	Approved	SCALE	UNIT
CBL-HFD3SAB5C-xm				mm
Drawing Name		Drawn	Date	REV.
USB 3.1 GEN 1 A to C Cable M/M				1.0

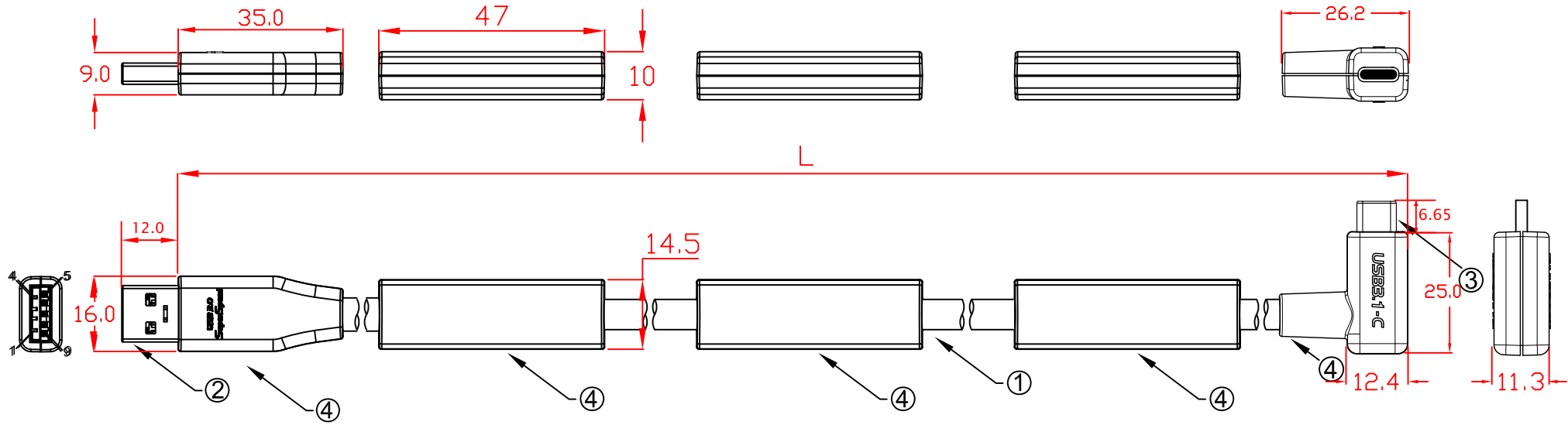

L:
 CBL-HFD3SAB5C-7mLRA 7000mm±50mm
 CBL-HFD3SAB5C-8mLRA 8000mm±50mm
 CBL-HFD3SAB5C-9mLRA 9000mm±50mm

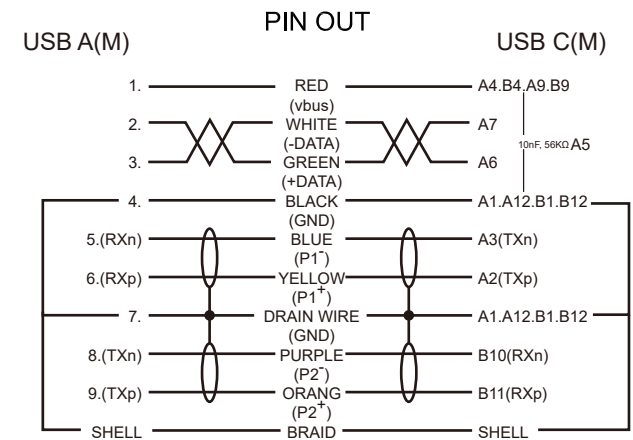

No	MATERIALS LIST:
1.	CABLE: 3 x (2 x 28 AWG)ST + 2 x 26 AWG O.D.:.6.1mm COLOR:RED LILAC
2.	CONNECTOR:USB 3.0 A/M, 9P, BLUE INSULATOR SOLDER TYPE, NICKEL PLATED SHELL
3.	CONNECTOR:USB 3.1 TYPE-C, MALE, NICKEL PLATED SHELL
4.	ABS ASSEMBLY HOUSING, BLACK COLOR
5.	

Jargy part no.	Client part no.	Approved	SCALE	UNIT
CBL-HFD3SAB5C-xmLRA				mm
Drawing Name		Drawn	Date	REV.
USB 3.1 GEN 1 A to C Cable M/M				1.0

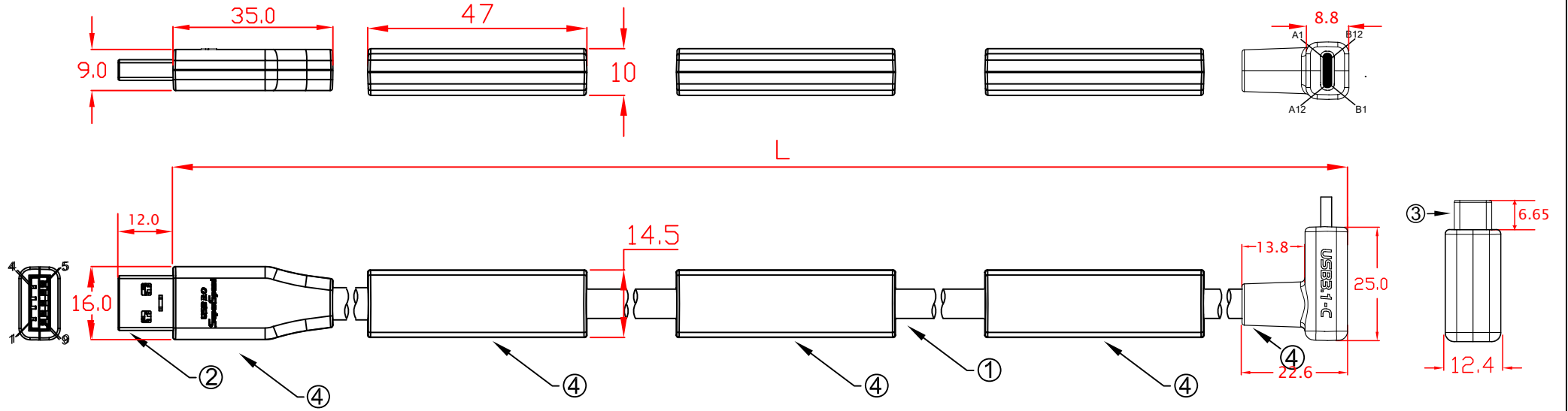

L:
 CBL-HFD3SAB5C-7mUDA 7000mm±50mm
 CBL-HFD3SAB5C-8mUDA 8000mm±50mm
 CBL-HFD3SAB5C-9mUDA 9000mm±50mm

No	MATERIALS LIST:
1.	CABLE: 3 x (2 x 28 AWG)ST + 2 x 26 AWG O.D.:6.1mm COLOR:RED LILAC
2.	CONNECTOR:USB 3.0 A/M, 9P, BLUE INSULATOR SOLDER TYPE, NICKEL PLATED SHELL
3.	CONNECTOR:USB 3.1 TYPE-C, MALE, NICKEL PLATED SHELL
4.	ABS ASSEMBLY HOUSING, BLACK COLOR
5.	

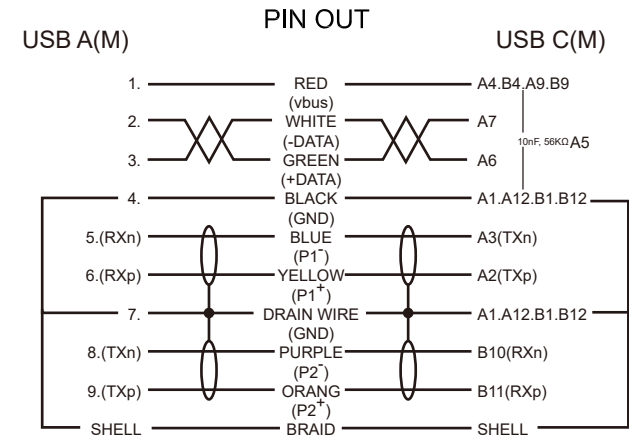

Jargy part no.	Client part no.	Approved	SCALE	UNIT
CBL-HFD3SAB5C-xmUDA				mm
Drawing Name		Drawn	Date	REV.
USB 3.1 GEN 1 A to C Cable M/M				1.0

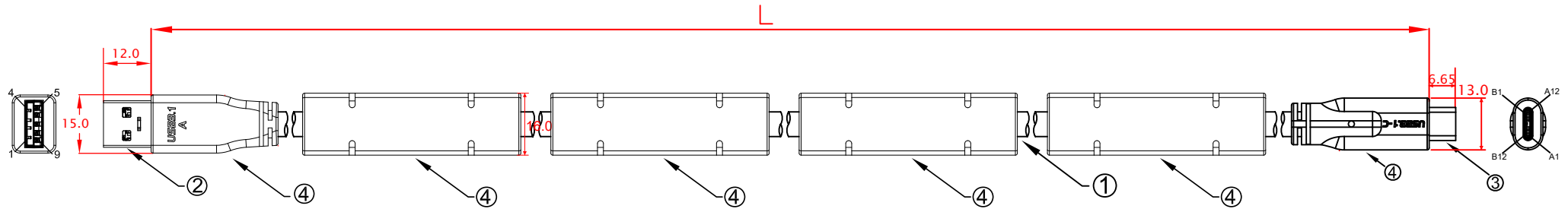
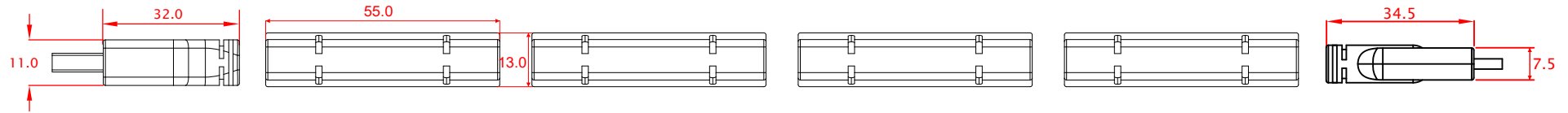

L:
 CBL-HFD3SAB5C-10m 10000mm±50mm
 CBL-HFD3SAB5C-11m 11000mm±50mm
 CBL-HFD3SAB5C-12m 12000mm±50mm

No	MATERIALS LIST:
1.	CABLE: 3 x (2 x 28 AWG)ST + 2 x 26 AWG O.D.:.6.1mm COLOR:RED LILAC
2.	CONNECTOR:USB 3.0 A/M, 9P, BLUE INSULATOR SOLDER TYPE, NICKEL PLATED SHELL
3.	CONNECTOR:USB 3.1 TYPE-C, MALE, NICKEL PLATED SHELL
4.	PVC MOLDED HOUSING, BLACK COLOR

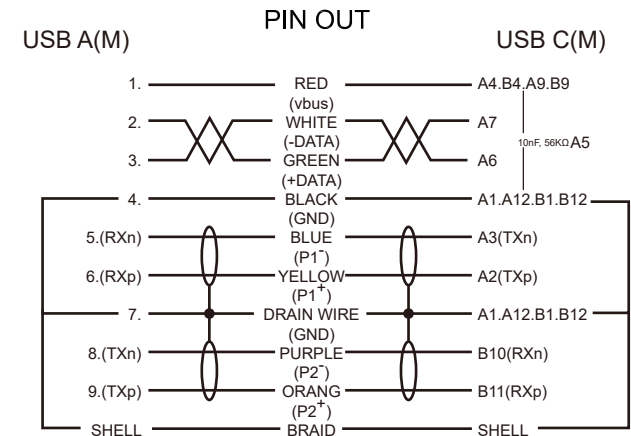

Jargy part no.	Client part no.	Approved	SCALE	UNIT
CBL-HFD3SAB5C-xm				mm
Drawing Name		Drawn	Date	REV.
USB 3.1 GEN 1 A to C Cable M/M				1.0

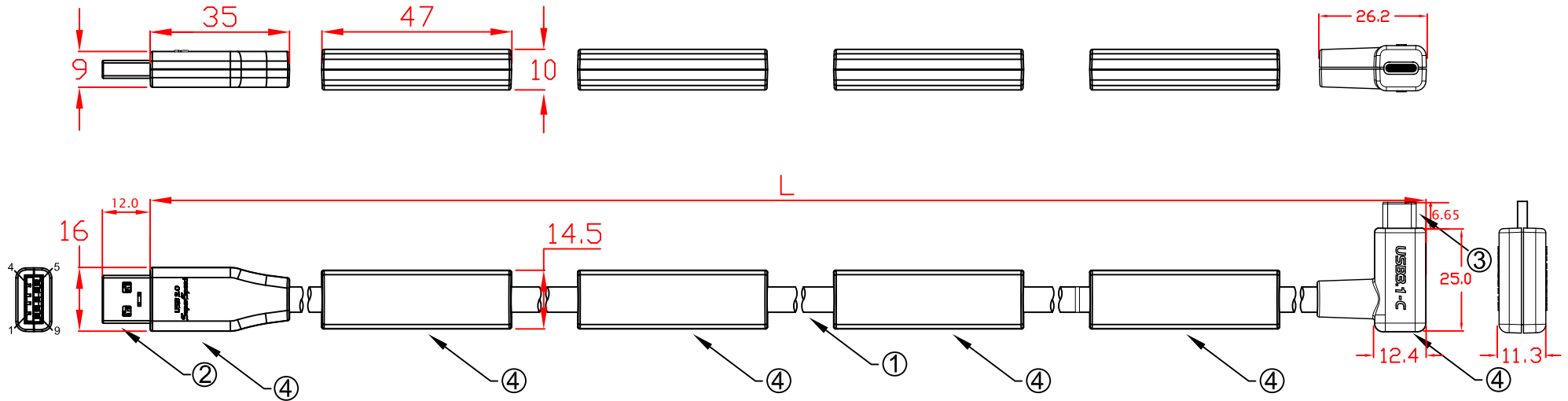

L:
 CBL-HFD3SAB5C-10mLRA 10000mm±50mm
 CBL-HFD3SAB5C-11mLRA 11000mm±50mm
 CBL-HFD3SAB5C-12mLRA 12000mm±50mm

No	MATERIALS LIST:
1.	CABLE: 3 x (2 x 28 AWG)ST + 2 x 26 AWG O.D.:6.1mm COLOR:RED LILAC
2.	CONNECTOR:USB 3.0 A/M, 9P, BLUE INSULATOR SOLDER TYPE, NICKEL PLATED SHELL
3.	CONNECTOR:USB 3.1 TYPE-C, MALE, NICKEL PLATED SHELL
4.	ABS ASSEMBLY HOUSING, BLACK COLOR

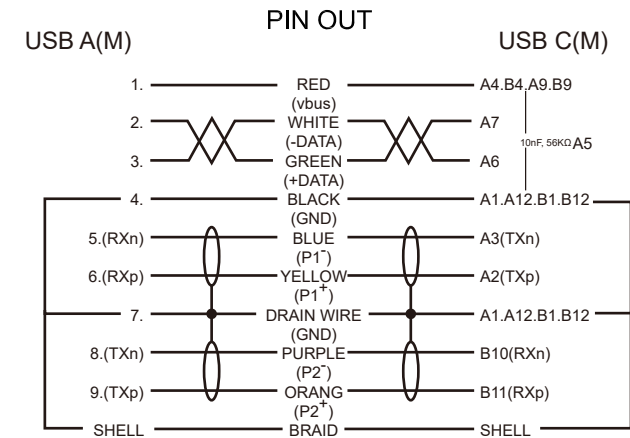

Jargy part no.	Client part no.	Approved	SCALE	UNIT
CBL-HFD3SAB5C-xmLRA				mm
Drawing Name		Drawn	Date	REV.
USB 3.1 GEN 1 A to C Cable M/M				1.0

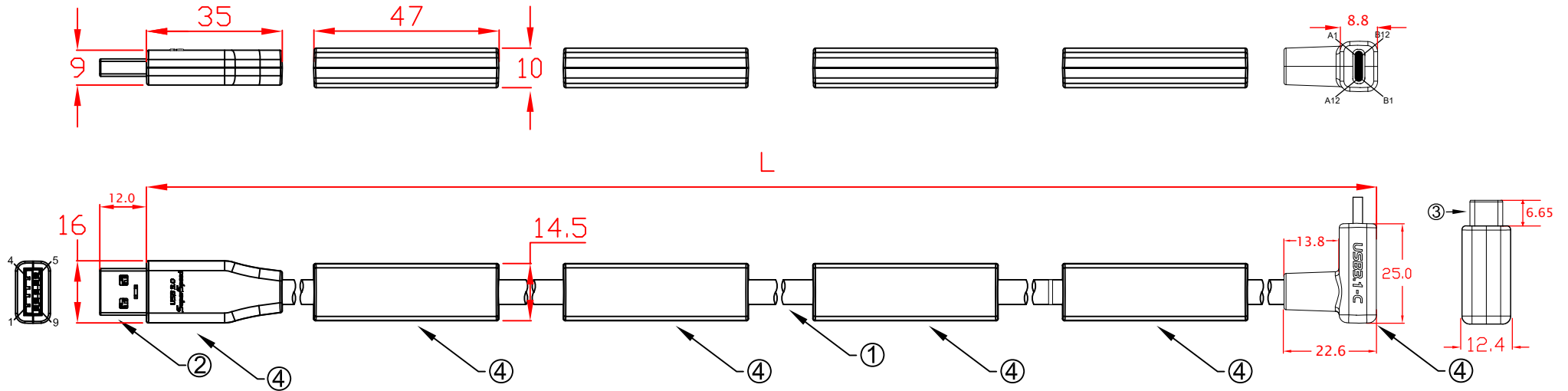

L:
 CBL-HFD3SAB5C-10mUDA 10000mm±50mm
 CBL-HFD3SAB5C-11mUDA 11000mm±50mm
 CBL-HFD3SAB5C-12mUDA 12000mm±50mm

No	MATERIALS LIST:
1.	CABLE: 3 x (2 x 28 AWG)ST + 2 x 26 AWG O.D.:.6.1mm COLOR:RED LILAC
2.	CONNECTOR:USB 3.0 A/M, 9P, BLUE INSULATOR SOLDER TYPE, NICKEL PLATED SHELL
3.	CONNECTOR:USB 3.1 TYPE-C, MALE, NICKEL PLATED SHELL
4.	ABS ASSEMBLY HOUSING, BLACK COLOR

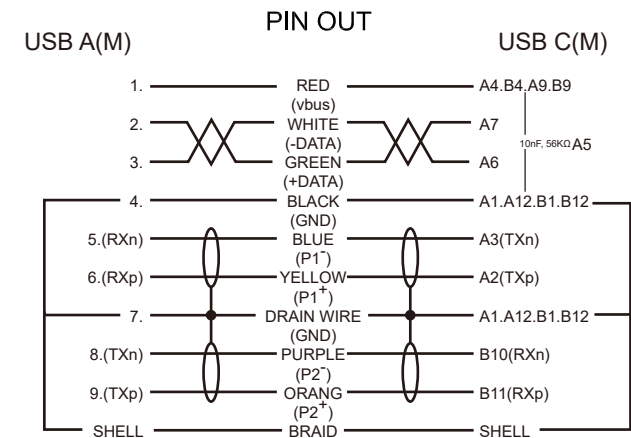

Jargy part no.	Client part no.	Approved	SCALE	UNIT
CBL-HFD3SAB5C-xmUDA				mm
Drawing Name		Drawn	Date	REV.
USB 3.1 GEN 1 A to C Cable M/M				1.0

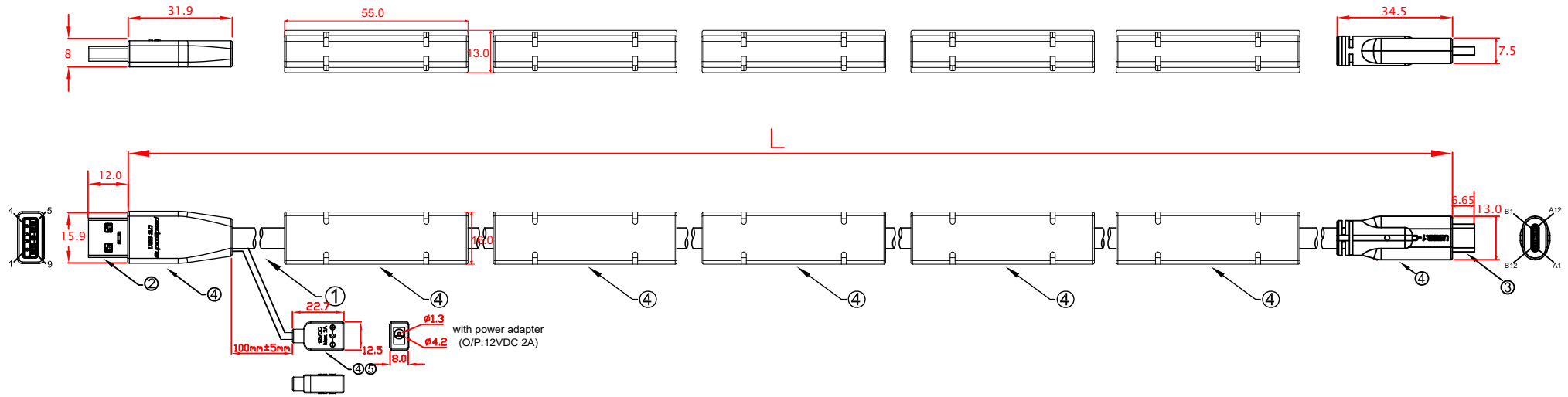

- L:
- CBL-HFD3SAB5CPW-13m 13000mm±50mm
 - CBL-HFD3SAB5CPW-14m 14000mm±50mm
 - CBL-HFD3SAB5CPW-15m 15000mm±50mm

No	MATERIALS LIST:
1.	CABLE: 3 x (2 x 28 AWG)ST + 2 x 26 AWG O.D.:.6.1mm COLOR:RED LILAC
2.	CONNECTOR:USB 3.0 A/M, 9P, BLUE INSULATOR SOLDER TYPE, NICKEL PLATED SHELL
3.	CONNECTOR:USB 3.1 TYPE-C, MALE, NICKEL PLATED SHELL
4.	PVC MOLDED HOUSING, BLACK COLOR
5.	DC JACK 1.3mm 30V 0.3V

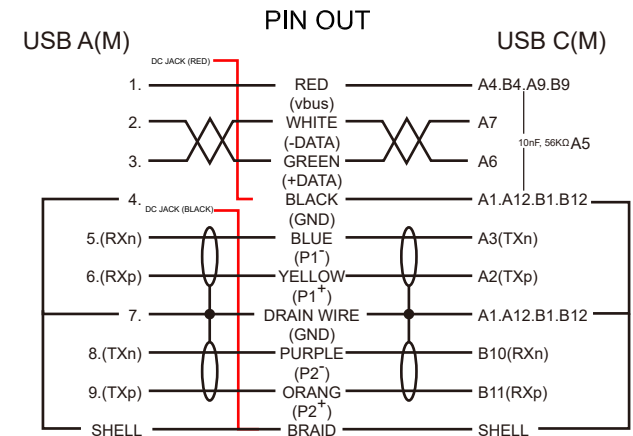

Jargy part no.	Client part no.	Approved	SCALE	UNIT
CBL-HFD3SAB5CPW-xm				mm
Drawing Name		Drawn	Date	REV.
USB 3.1 GEN 1 A to C Cable M/M				1.0

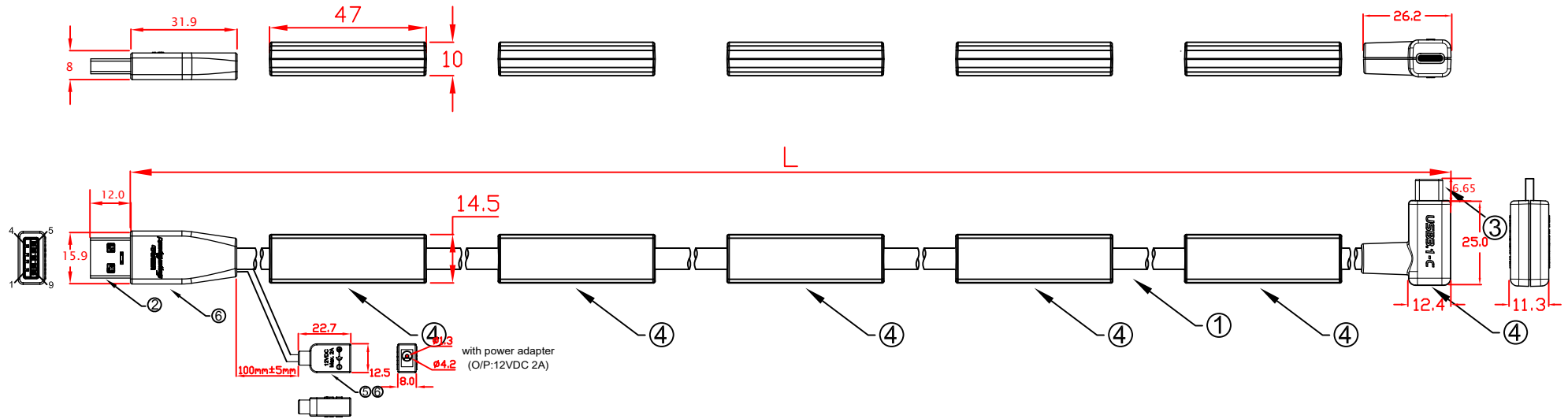

- L:
 CBL-HFD3SAB5CPW-13mLRA 13000mm±50mm
 CBL-HFD3SAB5CPW-14mLRA 14000mm±50mm
 CBL-HFD3SAB5CPW-15mLRA 15000mm±50mm

No	MATERIALS LIST:
1.	CABLE: 3 x (2 x 28 AWG)ST + 2 x 26 AWG O.D.:.6.1mm COLOR:RED LILAC
2.	CONNECTOR:USB 3.0 A/M, 9P, BLUE INSULATOR SOLDER TYPE, NICKEL PLATED SHELL
3.	CONNECTOR:USB 3.1 TYPE-C, MALE, NICKEL PLATED SHELL
4.	ABS ASSEMBLY HOUSING, BLACK COLOR
5.	DC JACK 1.3mm 30V 0.3V
6.	PVC MOLDED HOUSING, BLACK COLOR

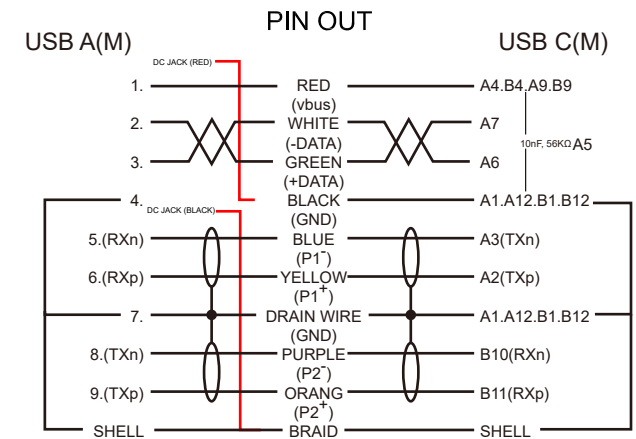

Jargy part no.	Client part no.	Approved	SCALE	UNIT
CBL-HFD3SAB5CPW-xmLRA				mm
Drawing Name		Drawn	Date	REV.
USB 3.1 GEN 1 A to C Cable M/M				1.0

Mobile Computing **JARGY**

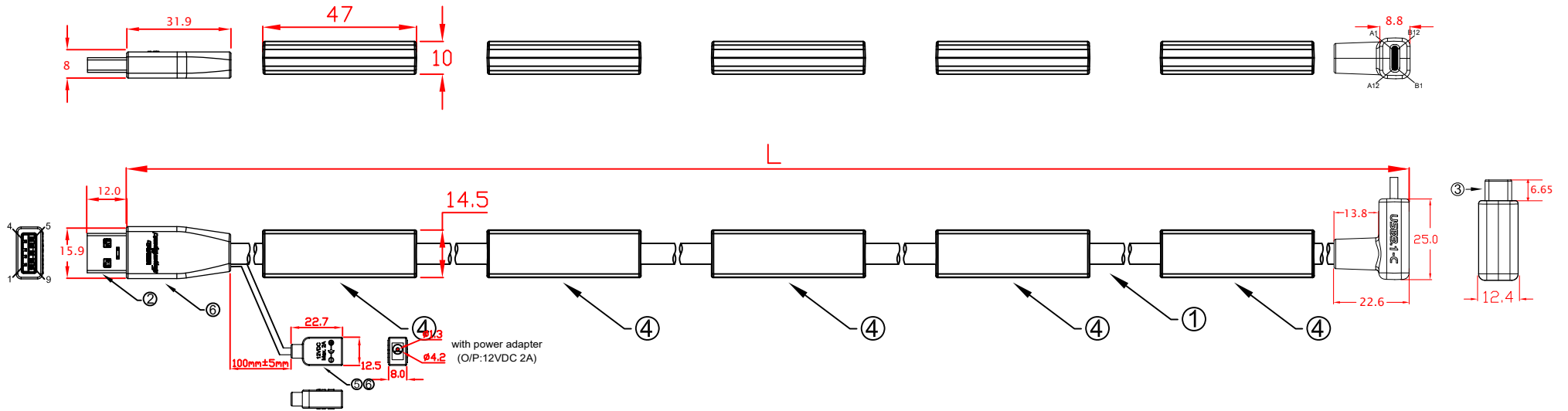

- L:
 CBL-HFD3SAB5CPW-13mUDA 13000mm±50mm
 CBL-HFD3SAB5CPW-14mUDA 14000mm±50mm
 CBL-HFD3SAB5CPW-15mUDA 15000mm±50mm

No	MATERIALS LIST:
1.	CABLE: 3 x (2 x 28 AWG)ST + 2 x 26 AWG O.D.:.6.1mm COLOR:RED LILAC
2.	CONNECTOR:USB 3.0 A/M, 9P, BLUE INSULATOR SOLDER TYPE, NICKEL PLATED SHELL
3.	CONNECTOR:USB 3.1 TYPE-C, MALE, NICKEL PLATED SHELL
4.	ABS ASSEMBLY HOUSING, BLACK COLOR
5.	DC JACK 1.3mm 30V 0.3V
6.	PVC MOLDED HOUSING, BLACK COLOR

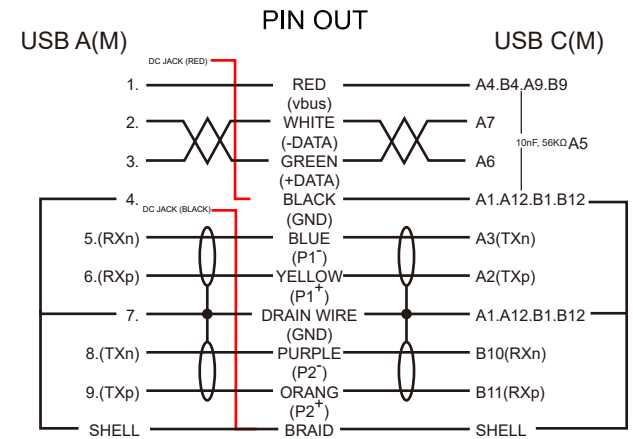

Jargy part no.	Client part no.	Approved	SCALE	UNIT
CBL-HFD3SAB5CPW-xmUDA				mm
Drawing Name		Drawn	Date	REV.
USB 3.1 GEN 1 A to C Cable M/M				1.0

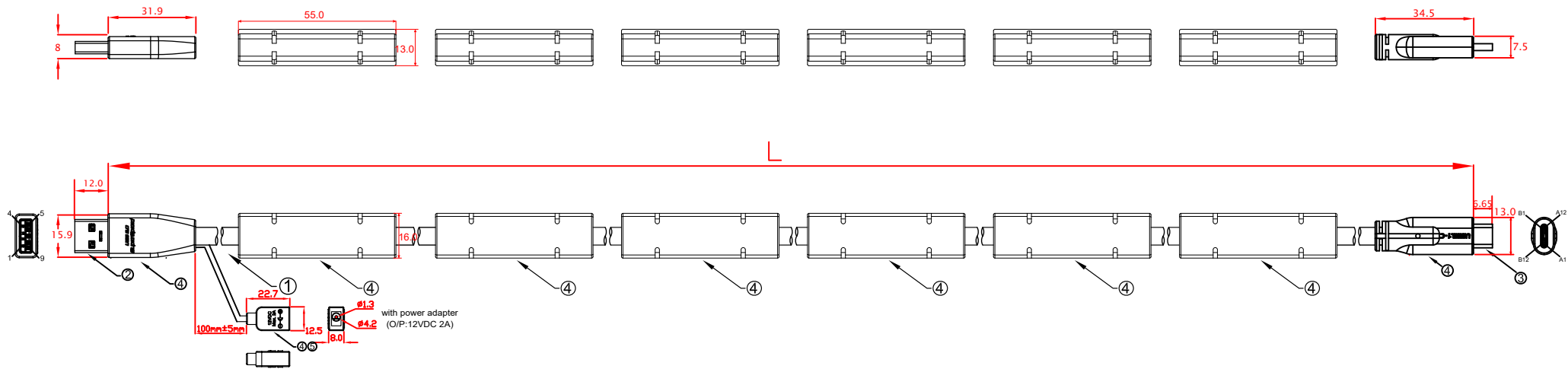

- L:
- CBL-HFD3SAB5CPW-16m 16000mm±50mm
 - CBL-HFD3SAB5CPW-17m 17000mm±50mm
 - CBL-HFD3SAB5CPW-18m 18000mm±50mm
 - CBL-HFD3SAB5CPW-19m 19000mm±50mm
 - CBL-HFD3SAB5CPW-20m 20000mm±50mm

No	MATERIALS LIST:
1.	CABLE: 3 x (2 x 28 AWG)ST + 2 x 26 AWG O.D.:.6.1mm COLOR:RED LILAC
2.	CONNECTOR:USB 3.0 A/M, 9P, BLUE INSULATOR SOLDER TYPE, NICKEL PLATED SHELL
3.	CONNECTOR:USB 3.1 TYPE-C, MALE, NICKEL PLATED SHELL
4.	PVC MOLDED HOUSING, BLACK COLOR
5.	DC JACK 1.3mm 30V 0.3V

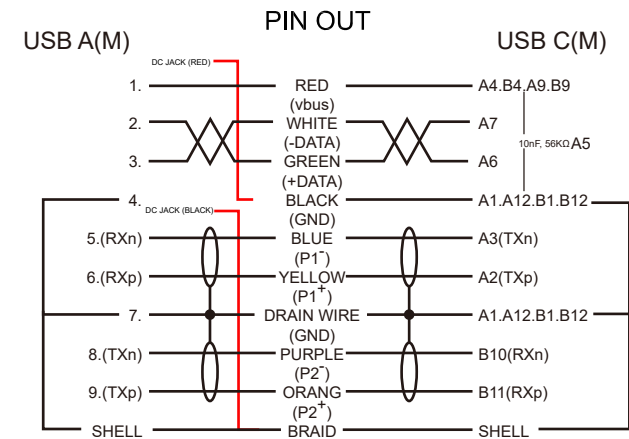

Jargy part no.	Client part no.	Approved	SCALE	UNIT
CBL-HFD3SAB5CPW-xm				mm
Drawing Name		Drawn	Date	REV.
USB 3.1 GEN 1 A to C Cable M/M				1.0

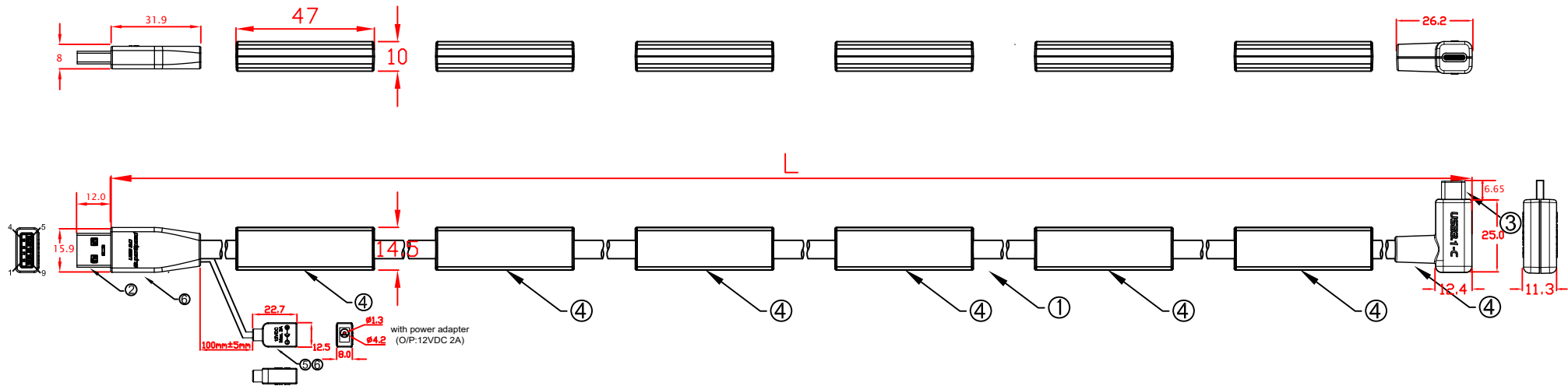

L:

CBL-HFD3SAB5CPW-16mLRA	16000mm±50mm
CBL-HFD3SAB5CPW-17mLRA	17000mm±50mm
CBL-HFD3SAB5CPW-18mLRA	18000mm±50mm
CBL-HFD3SAB5CPW-19mLRA	19000mm±50mm
CBL-HFD3SAB5CPW-20mLRA	20000mm±50mm

No	MATERIALS LIST:
1.	CABLE: 3 x (2 x 28 AWG)ST + 2 x 26 AWG O.D.:6.1mm COLOR:RED LILAC
2.	CONNECTOR:USB 3.0 A/M, 9P, BLUE INSULATOR SOLDER TYPE, NICKEL PLATED SHELL
3.	CONNECTOR:USB 3.1 TYPE-C, MALE, NICKEL PLATED SHELL
4.	ABS ASSEMBLY HOUSING, BLACK COLOR
5.	DC JACK 1.3mm 30V 0.3V
6.	PVC MOLDED HOUSING, BLACK COLOR

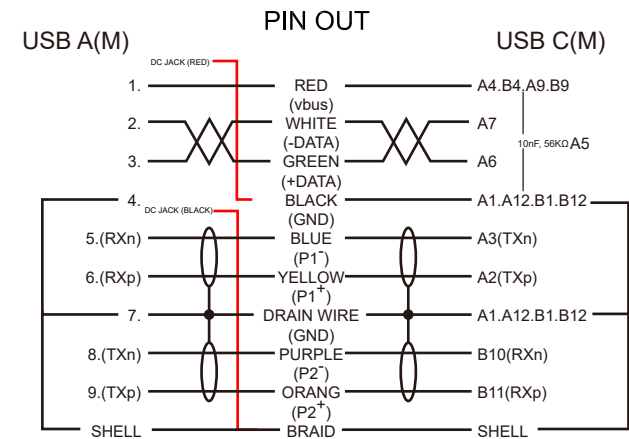

Jargy part no.	Client part no.	Approved	SCALE	UNIT
CBL-HFD3SAB5CPW-xmlLRA				mm
Drawing Name		Drawn	Date	REV.
USB 3.1 GEN 1 A to C Cable M/M				1.0

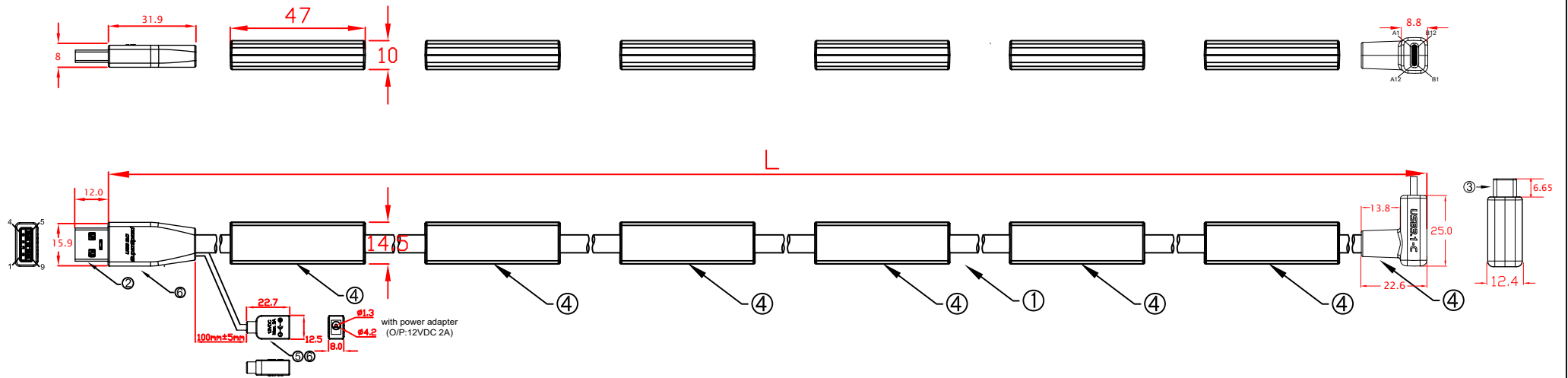

- L:
 CBL-HFD3SAB5CPW-16mUDA 16000mm±50mm
 CBL-HFD3SAB5CPW-17mUDA 17000mm±50mm
 CBL-HFD3SAB5CPW-18mUDA 18000mm±50mm
 CBL-HFD3SAB5CPW-19mUDA 19000mm±50mm
 CBL-HFD3SAB5CPW-20mUDA 20000mm±50mm

No	MATERIALS LIST:
1.	CABLE: 3 x (2 x 28 AWG)ST + 2 x 26 AWG O.D.:.6.1mm COLOR:RED LILAC
2.	CONNECTOR:USB 3.0 A/M, 9P, BLUE INSULATOR SOLDER TYPE, NICKEL PLATED SHELL
3.	CONNECTOR:USB 3.1 TYPE-C, MALE, NICKEL PLATED SHELL
4.	ABS ASSEMBLY HOUSING, BLACK COLOR
5.	DC JACK 1.3mm 30V 0.3V
6.	PVC MOLDED HOUSING, BLACK COLOR

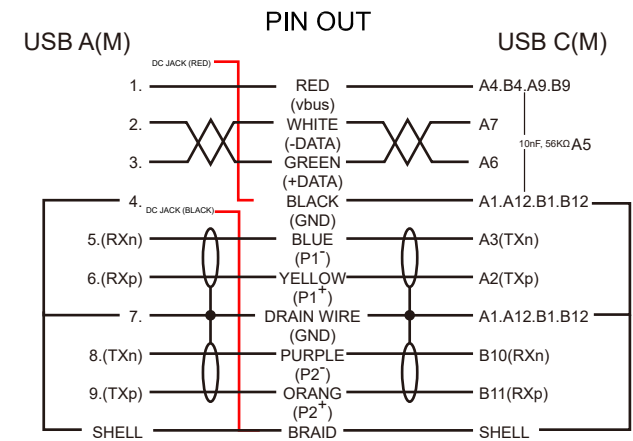

Jargy part no.	Client part no.	Approved	SCALE	UNIT
CBL-HFD3SAB5CPW-xmUDA				mm
Drawing Name		Drawn	Date	REV.
USB 3.1 GEN 1 A to C Cable M/M				1.0